

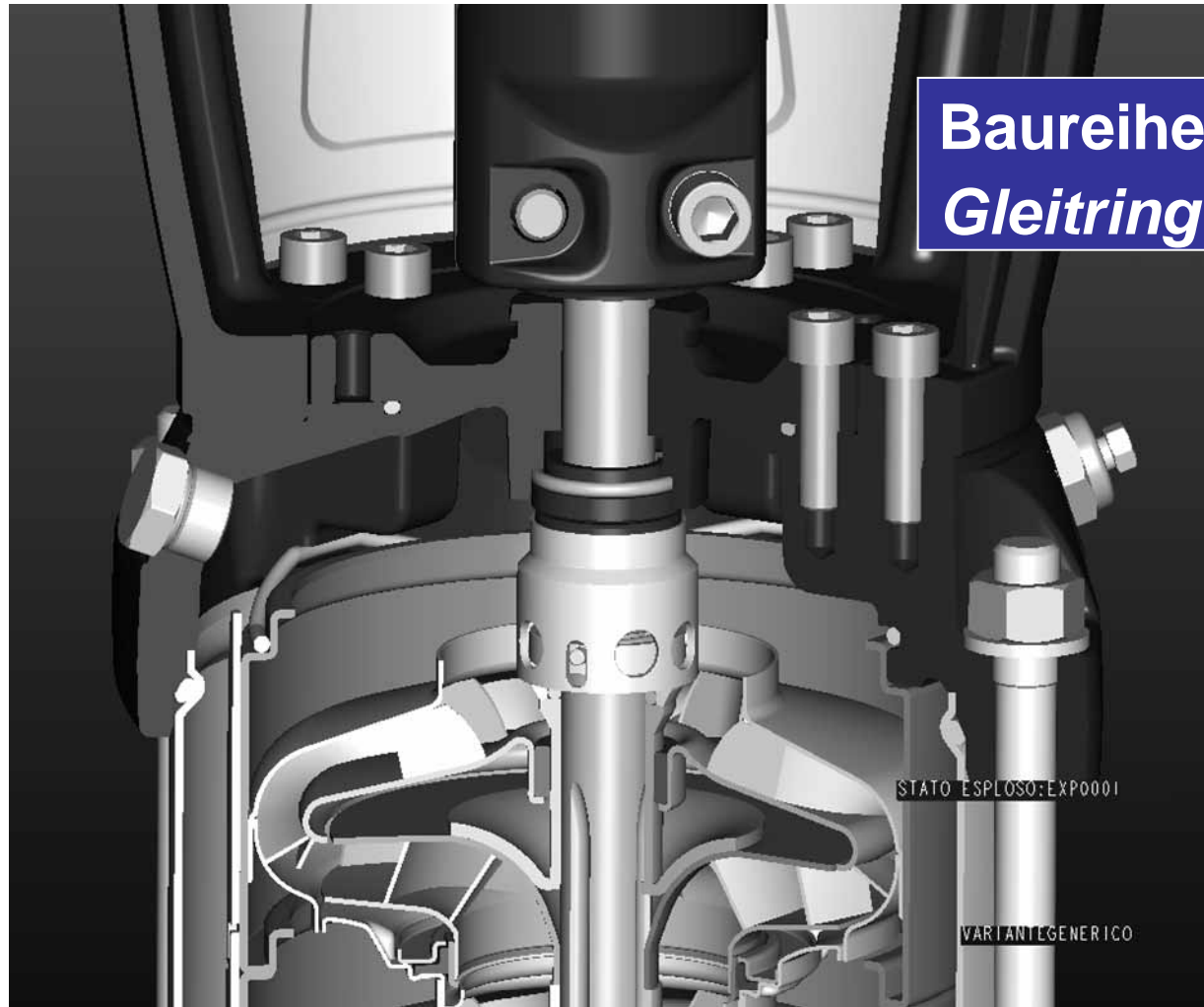

ITT



Baureihe SV 33-92 *Gleitringsdichtung wechseln*

HINWEIS: Zum Wechseln der Gleitringsdichtung muss der Motor nicht demontiert werden!



ITT



Kupplungsschutz abschrauben



ITT

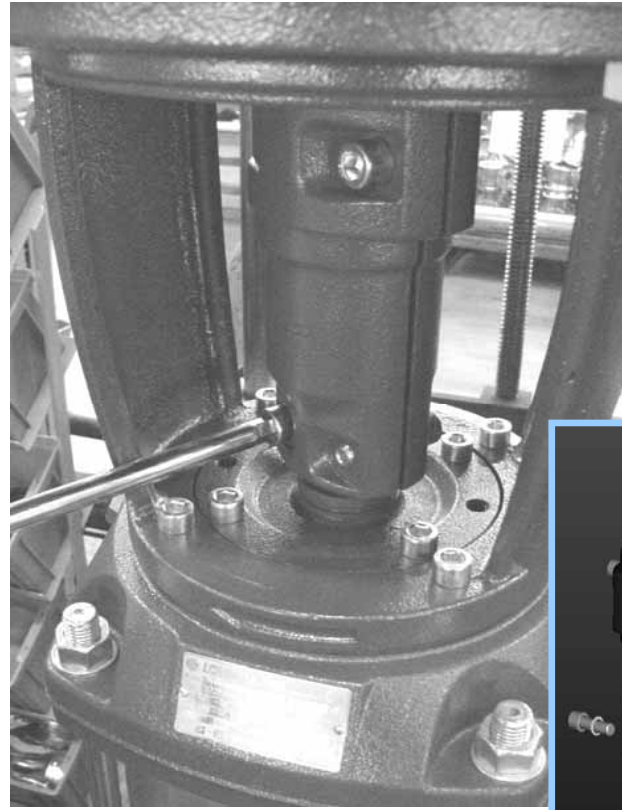
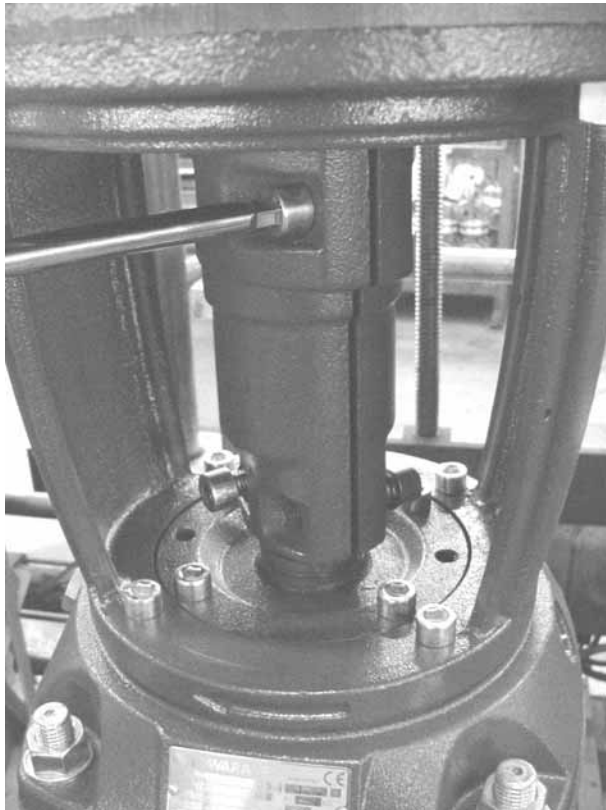

Kupplungsschrauben lösen

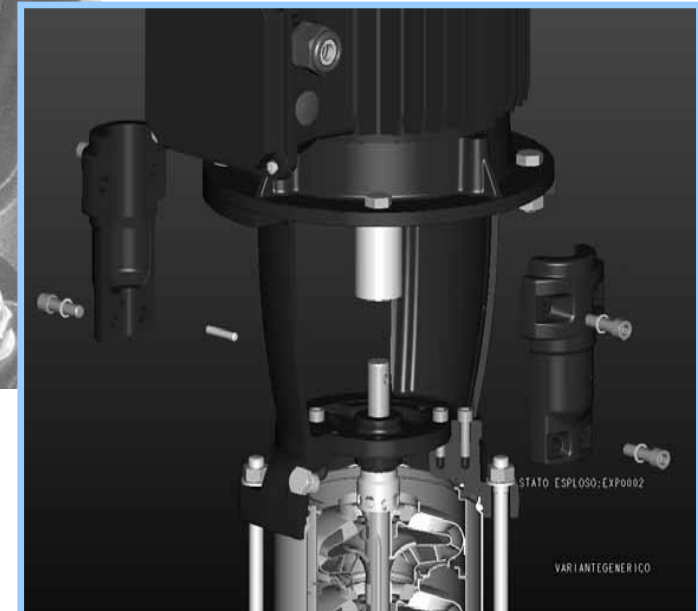



ITT

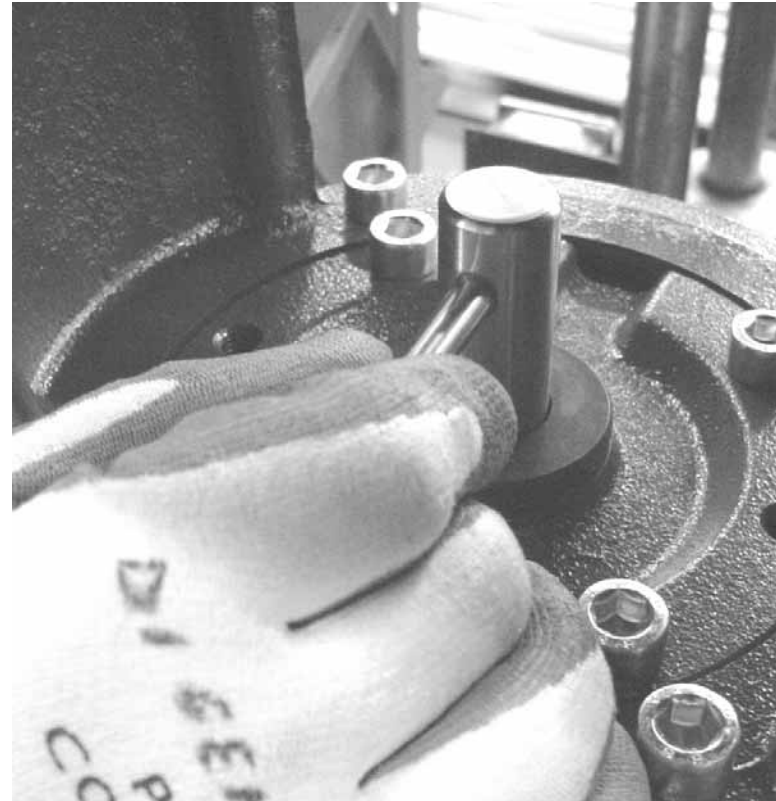

Kupplungshälften und Mitnehmerstift ausbauen



ITT

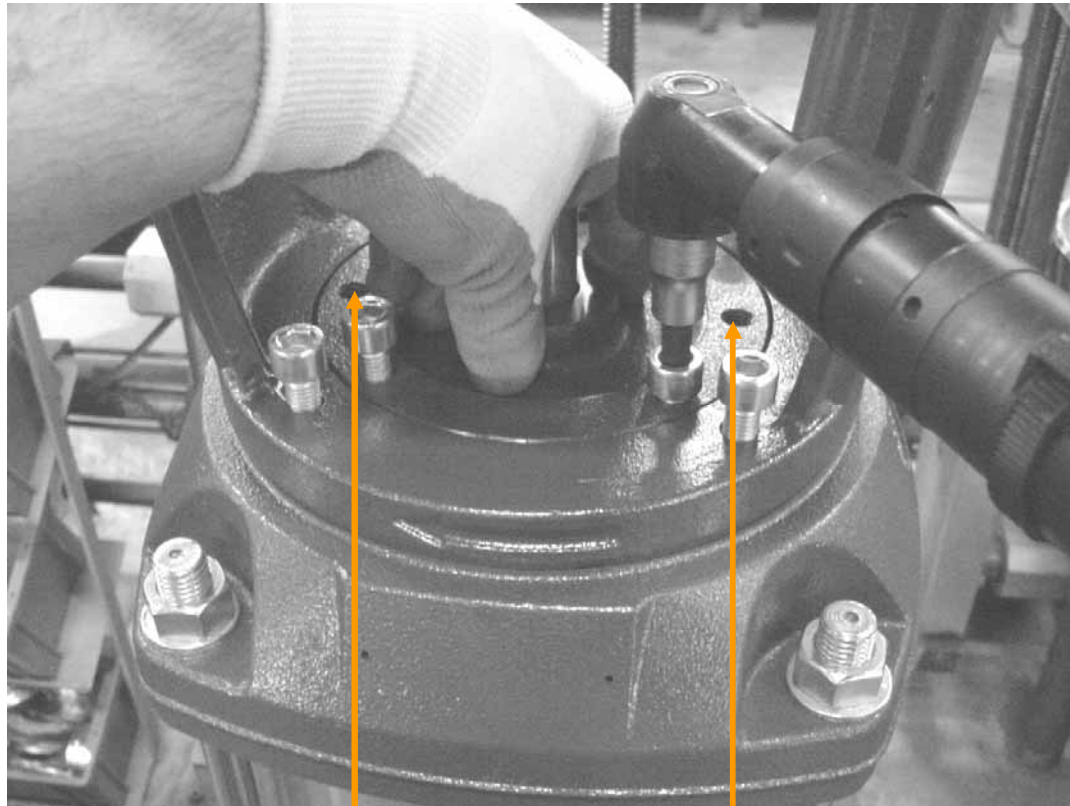

Bohrungen zum Abdrücken

Ausbau des Dichtungsdeckels

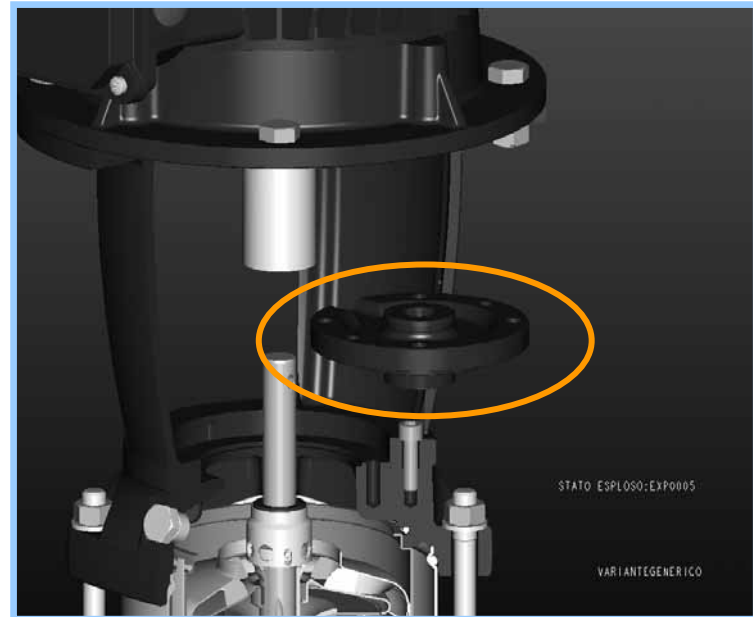



ITT

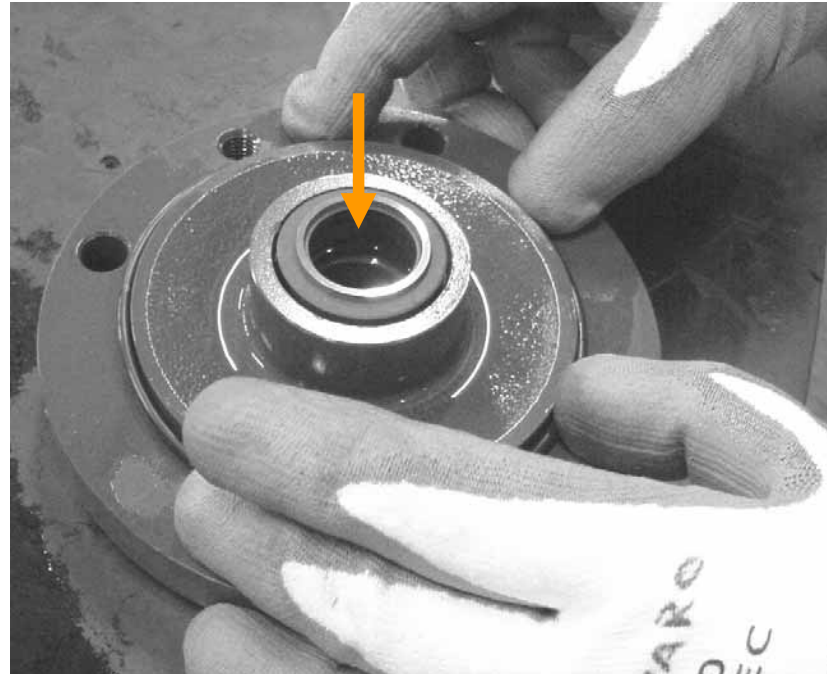
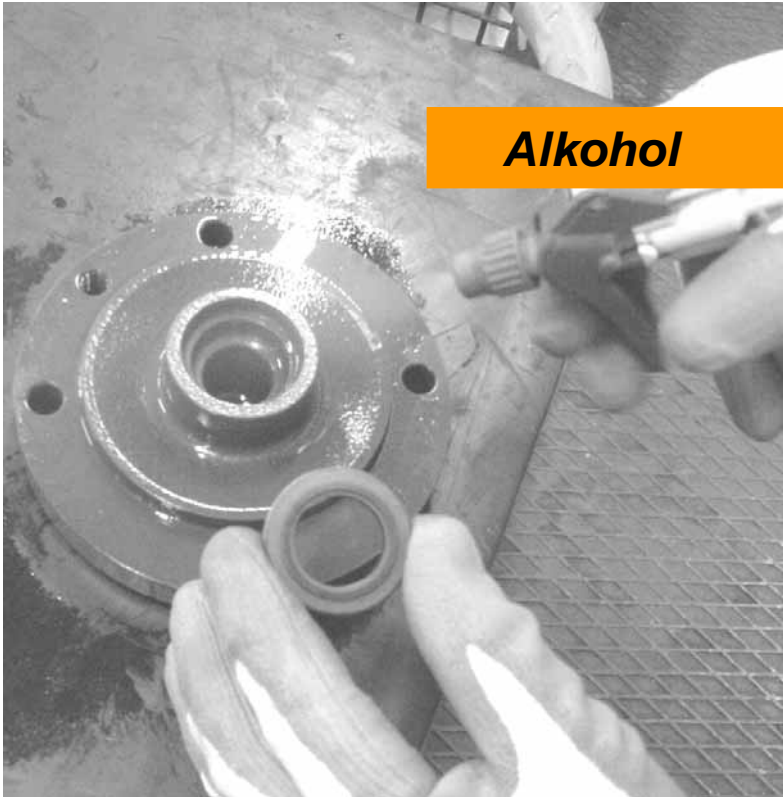

**Austausch des stationären Rings
der Gleitringdichtung**

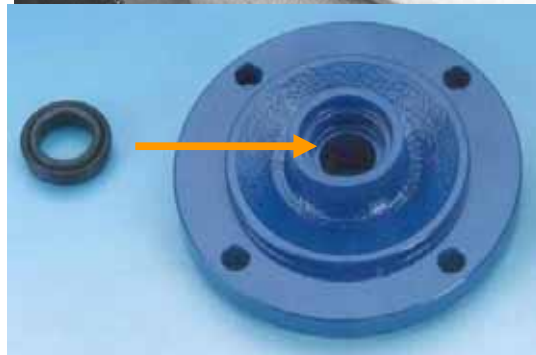



ITT



Mitnehmer

Bohrungen

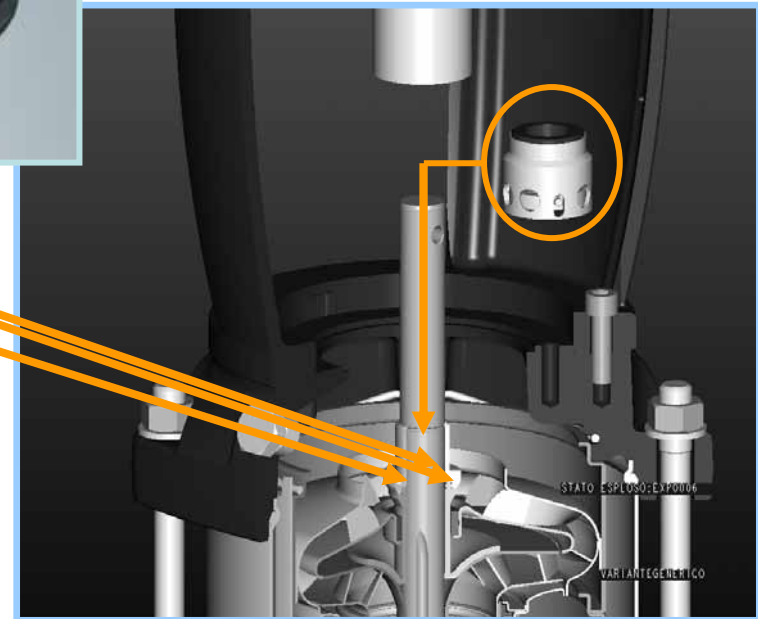

Austausch des rotierenden Teils der Gleitringdichtung (keine Werkzeuge verwenden!)
Die Mitnehmerstifte müssen in den passenden Bohrungen in der Distanzhülse sitzen.



ITT



Einbau des Dichtungsdeckels

Schrauben über Kreuz anziehen, Drehmoment beachten.



ITT

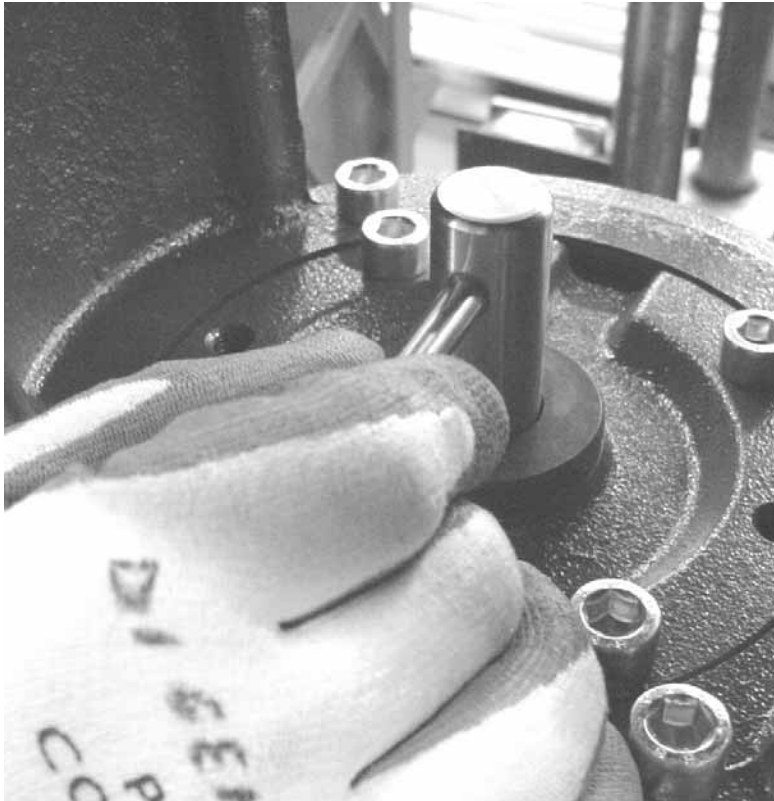

Mitnehmerstift und Kupplungshälften einbauen



ITT



**Welle ausrichten mit
– 5mm Schlüssel →**

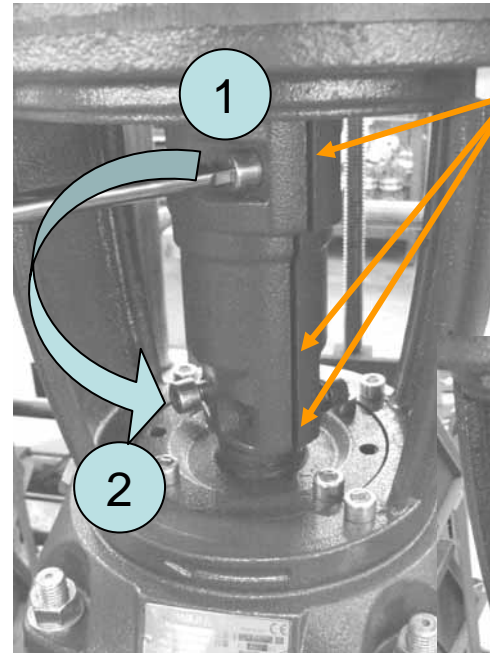
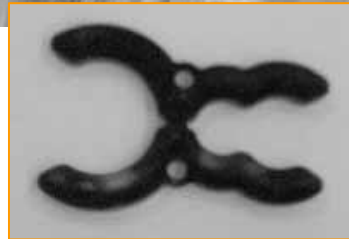

**Kupplung
festziehen.
Schrauben über
Kreuz anziehen.**

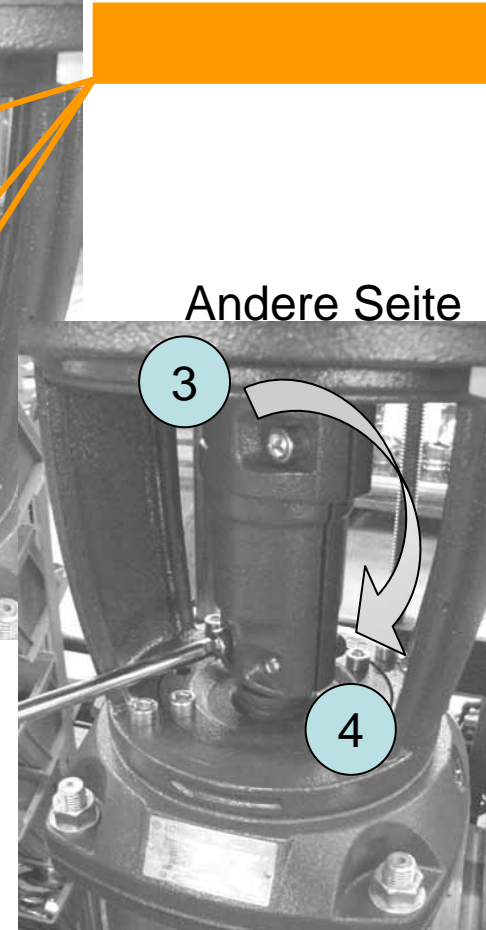



ITT



Kupplungsschutz montieren